

SUMMARY OF OVERVIEW ON EMBEDDED SYSTEMS

1Sadia Kausar, 2Mohammed Ibrahim Ali, 3Shaik Zayd Ahmed Farooqui, 4Mohammed Misban Uddin
1Assistant Professor, Department of CSE-AIML, Lords Institute of Engineering & Technology.
234 Student Department of CSE-AIML, Lords Institute of Engineering & Technology.

Research Article

Date of Submission: 20-05-2025

Date of Acceptance: 19-05-2025

Date of Publication: 09-07-2025

ABSTRACT :

A short overview of embedded systems is provided in this study, including what an embedded system is or is defined as, its components, necessary operating systems, supporting software, applications, benefits, and drawbacks.

INTRODUCTION :

Together with the software that manages it, an embedded system is a hardware system created to address a particular issue. Robots, automobiles, medical equipment, and tiny IoT gadgets might all be involved.

A computer that supports a machine is another way to describe an embedded system. In the larger machine, it carries out a single duty. Traffic lights, digital TVs, ATMs, airline controls, point-of-sale (PoS) terminals, digital cameras, GPS navigation systems, elevators, smart meters, and automobile computer systems are a few examples.

ABOUT RESEARCH :

This research contain brief introduction about embedded systems like What is an embedded system or definition of embedded system ,components of embedded systems ,required operating systems ,supporting softwares, applications of embedded systems ,advantages & disadvantages. Description of working principal also there with step by step process.

To understand in easy way there is a basic diagram of embedded system in which mentioned essential parts of embedded system like Flash Storage, Clock source, Modular processor block, RAM, Processors ,Power Block Com. Interfaces ,Sensors & Other blocks (Fig 1).

In (Fig 2) hardware unit diagram also there in which memory, CPU, sensors, actuators mentioned. In (Fig 3) Layered architecture of an embedded system mentioned.

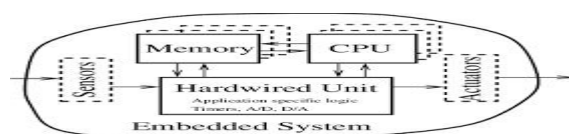
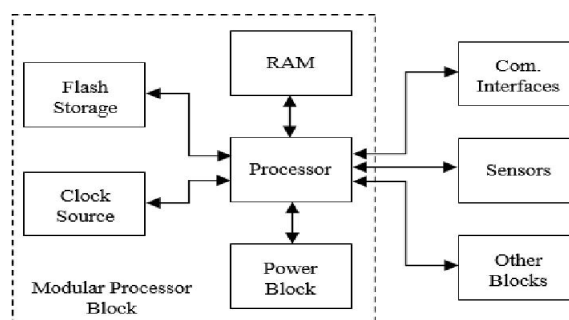
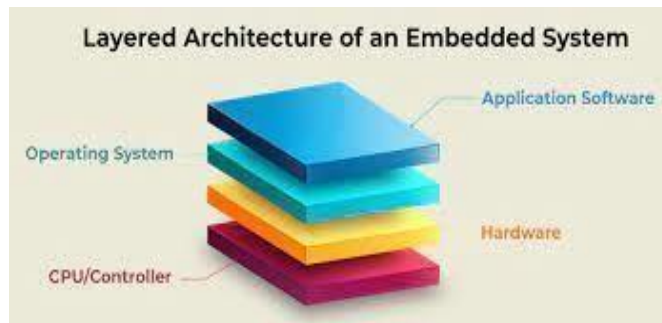

Fig 3



EMBEDDED SYSTEMS :

DEFINATION

A computer hardware and software combination created for a particular purpose is called an embedded system. Additionally, embedded systems may operate within of a larger system. The systems may have fixed functionality or be configurable. An embedded system may be found in consumer electronics, industrial machinery, agricultural and processing sector devices, cars, medical equipment, cameras, digital watches, home appliances, aircraft, vending machines, toys, and mobile devices.

WORKING

A CPU, memory, and the required input/output (I/O) devices are usually included in embedded systems in order to offer the required functionality.

1. Data is controlled or processed by the microprocessor in accordance with commands from software applications that are kept in memory.
2. Basic serial communication protocols like I2C and SPI may be used to convey this data between components.
3. Moreover, embedded systems sometimes come with specialized hardware for operations like real-time clock functions and analog-to-digital conversion, which aid in accuracy under strict time limitations.
4. Lastly, a lot of external peripherals provide apps access to extra physical inputs or outputs such wireless interfaces, sensors, actuators, and displays.
5. These are linked by specific ports on the CPU board or an extension bus (like USB) that links many devices at once.

Classification of Embedded Systems

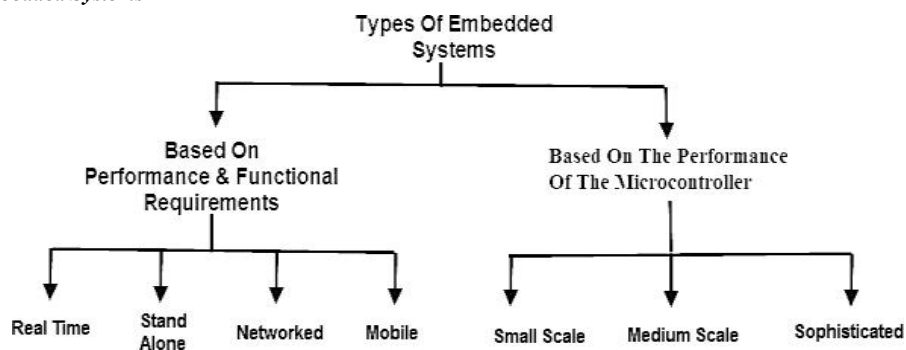

Applications of Embedded Systems:

Automotive and Telecommunications Embedded Systems

1. The cruise control and motor system
2. Engine or body safety
3. Car entertainment and multimedia;
4. Mobile access and e-com
5. Assembly line robots
6. Communication via wireless
7. Networking and mobile computing

Embedded Systems in Smart Cards, Missiles and Satellites

1. Security systems
2. Telephone and banking
3. Defense and aerospace
4. Communication

Embedded Systems in Peripherals & Computer Networking

1. Displays and Monitors
2. Networking Systems
3. Image Processing
4. Network cards and printers

Embedded Systems in Consumer Electronics

1. Digital Cameras
2. Set top Boxes
3. High Definition TVs
4. DVDs

Embedded Systems Examples

There are many things with embedded systems incorporated in the Internet of Things (IoT), as well as in machine to machine (M2M) devices. Exceptionally versatile and adaptable, embedded systems can be found in all smart devices today. It is difficult to find a single portion of modern life that doesn't involve this technology.

Here are some of the real-life examples of embedded system applications.

1. Central heating systems
2. GPS systems
3. Fitness trackers
4. Medical devices
5. Automotive systems
6. Transit and fare collection
7. ATMs
8. Factory robots
9. Electric vehicle charging stations
10. Interactive kiosks

REFERENCES :

1. Jiménez, M., Palomera, R. and Couvertier, I., 2013. *Introduction to embedded systems*. Springer.
2. Sangiovanni-Vincentelli, Alberto L., and Alessandro Pinto. "An overview of embedded system design education at Berkeley." *ACM Transactions on Embedded Computing Systems (TECS)* 4, no. 3 (2005): 472-499.
3. Nakutis, Z. "Embedded systems power consumption measurement methods overview." *MATAVIMAI* 2, no. 44 (2009): 29-35.